

Computer Vision Integrated Pick and Place System

Hayrettin Karci¹, Gökhan Göktug² and M.Berke Baspinar³

¹Festo San. ve Tic. A.S., Tuzla, Istanbul, **Turkey**.
email: hayrettin_karci@festo.com

²Sabanci University, Mechatronics Program, Tuzla, Istanbul, **Turkey**.
email: ggoktug@sabanciuniv.edu

³Sabanci University, Leaders For Industry Program, Tuzla, Istanbul, **Turkey**.
email: berkeb@su.sabanciuniv.edu

Abstract

The role of vision integrated automation systems will be increasing in the future as the demand for performing efficient and flawless production increases in the industrial plants. So, the importance of building systems that can work coherently with vision technology has increased.

Such a need in the market encouraged us to develop a "Mechatronics Solution Setup". In this setup an industrial camera is integrated to a conveyor which is passing under a handling system which has three degrees of freedom and a pneumatic end-effector. The camera is identifying the color and the position of the products coming from a conveyor, and transmitting this information through ethernet to the IPC(Industrial PC). And according to the information provided the handling system is tracking the products in order to pick and place them into the correct boxes that are placed at both sides of the conveyor.

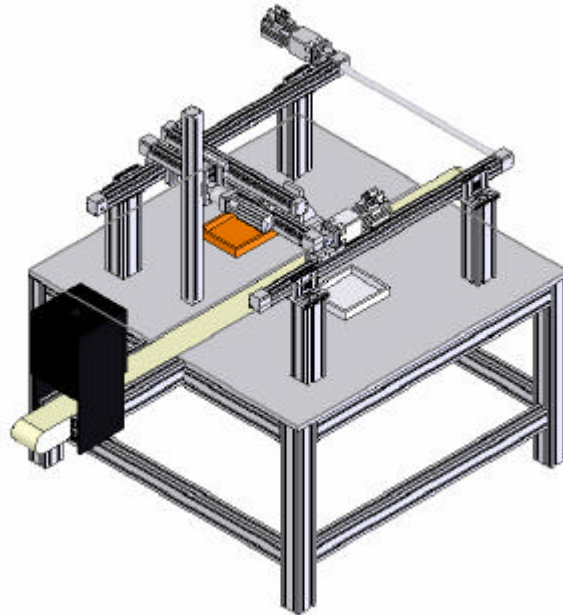

The aim of this paper is to describe the project which is developed in Festo-Turkey and the technologies employed in this project. This project constitutes a model for a generally defined problem. If the process parameters are defined, with minor modifications on the concept, it can be easily applied for different products in different industries.

Keywords: Handling, computer vision, quality control